

廠牌:

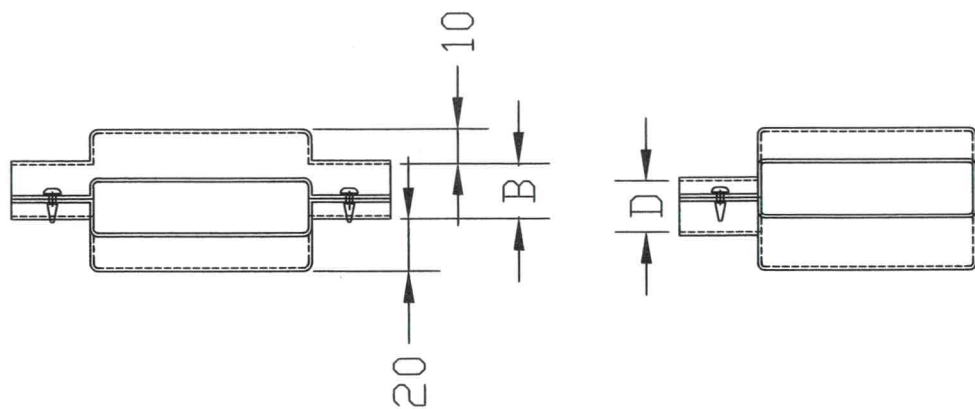

件號	A	B	C	D	(A)主銅板規格	(C)分路銅板規格	數量
T 01	45	15	45	15	10TX40-1/φ	10TX40-1/φ	
T 02	55	15	55	15	10TX50-1/φ	10TX50-1/φ	
T 03	65	15	65	15	10TX60-1/φ	10TX60-1/φ	
T 04	105	15	45	15	10TX100-1/φ	10TX40-1/φ	
T 05	55	35	55	15	10TX50-2/φ	10TX50-1/φ	
T 06	55	35	55	35	10TX50-2/φ	10TX50-2/φ	
T 07	105	35	85	35	10TX100-2/φ	10TX80-2/φ	
T 08	85	15	45	35	10TX80-1/φ	10TX40-2/φ	
T 09	85	15	85	15	10TX80-1/φ	10TX80-1/φ	
T 10	65	15	55	15	10TX60-1/φ	10TX50-1/φ	
T 11	55	15	35	15	10TX50-1/φ	10TX30-1/φ	
T 12	125	15	45	15	10TX120-1/φ	10TX40-1/φ	
T 13	105	15	55	35	10TX100-1/φ	10TX50-2/φ	
T 14	85	15	55	15	10TX80-1/φ	10TX50-1/φ	
T 15	105	15	55	15	10TX100-1/φ	10TX50-1/φ	
T 16	105	15	105	15	10TX100-1/φ	10TX100-1/φ	
T 17	85	45	85	35	10TX80-3/φ	10TX80-2/φ	
T 18	55	35	105	15	10TX50-2/φ	10TX100-1/φ	
T 19	85	15	55	35	10TX80-1/φ	10TX50-2/φ	
T 20	55	35	105	35	10TX50-2/φ	10TX100-2/φ	
T 21	105	35	105	35	10TX100-2/φ	10TX100-2/φ	
T 22	105	35	55	35	10TX100-2/φ	10TX50-2/φ	
T 23	45	35	55	15	10TX40-2/φ	10TX50-1/φ	
T 24	45	35	85	15	10TX40-2/φ	10TX80-1/φ	
T 25	85	15	45	15	10TX80-1/φ	10TX40-1/φ	
T 26	65	15	105	15	10TX60-2/φ	10TX100-2/φ	
T 27	105	15	65	15	10TX100-2/φ	10TX60-2/φ	
T 28	85	35	55	15	10TX80-2/φ	10TX50-1/φ	
T 29	125	55	125	55	10TX120-3/φ	10TX120-3/φ	
T 30	125	55	85	55	10TX120-3/φ	10TX80-3/φ	
T 31	105	35	55	15	10TX100-2/φ	10TX50-1/φ	
T 32	85	35	85	35	10TX80-2/φ	10TX80-2/φ	
T 33	85	35	85	15	10TX80-2/φ	10TX80-1/φ	
T 34	125	35	105	65	10TX120-2/φ	10TX100-4/φ	
T 35	55	15	55	35	10TX50-1/φ	10TX50-2/φ	
T 36	65	15	35	15	10TX60-1/φ	10TX30-1/φ	
T 37	65	35	65	35	10TX60-2/φ	10TX60-2/φ	
T 38	55	35	85	35	10TX50-1/φ	10TX80-1/φ	
T 39	105	15	65	15	10TX100-1/φ	10TX60-1/φ	

客戶工令:	宏于電機匯流排事業部 第三角圖法 3RD ANGLE PROJECTION 單位 mm 比例 / 日期 DATE	繪圖 DRAWN	設計 DESIGNED	校對 CHECKED	批准 APPROVED	送達時間: XXXXXX	案名:	A
宏于工令:		陳玉茹 103.12.08				送達地點: XXXX	備註:	SHEET NO.
圖名 TITLE T字型絕緣護套						收件人: XXX 先生	手機:	T1

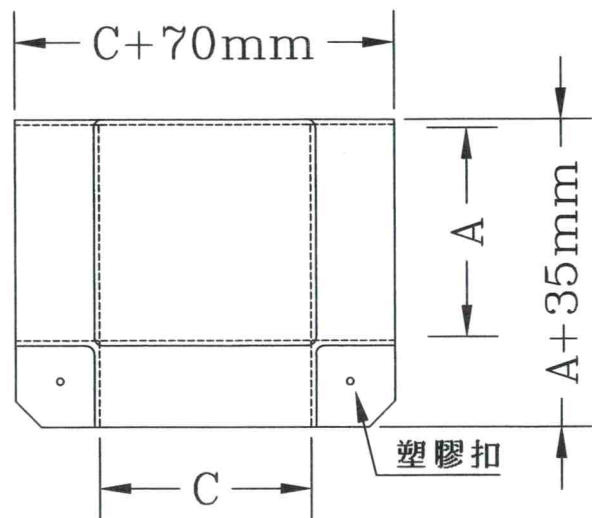