

溫度控制開關 TEMPERATURE CONTROLLER

LIQUID EXPANDING

液脹式溫度控制器



型號 Part No.	溫度調節範圍 Temp.Range	設定溫度差 Differential	感溫管長度 PROBE Length	規格 Spec.	毛細管 Capillary	
					長度 Length	材質 Material
CT-TH60	0°C~60°C	±3°C	120L 6Ø	單極雙投 S.P.D.T C1: 16A/10A 250V/380V C2: 6A/3A 250V/380V	1.000mm	SUS CU
CT-TH80	0°C~80°C	±4°C	72L 6Ø			
CT-TH120	30°C~120°C	±4°C	72L 6Ø			
CT-TH300	50°C~300°C	±10°C	153L 6Ø			

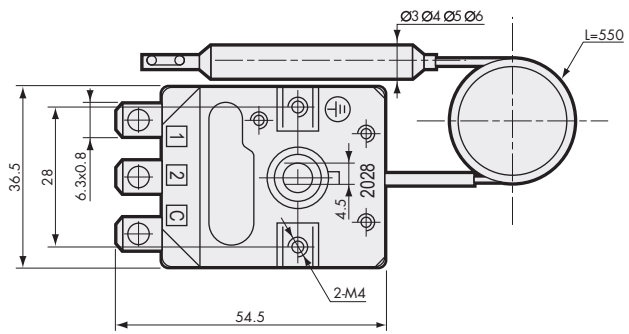
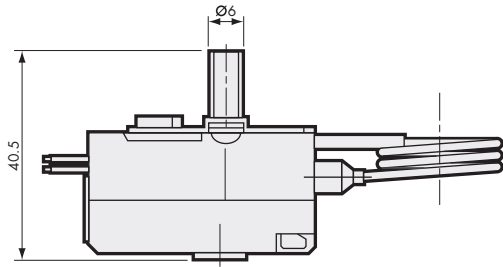

Unit: mm

MECHANICAL THERMOSTAT

機械式感應溫度控制開關

傳感組件: 恆溫雙片金屬, Sensing Components: Thermostat sheet metal

開關容量 Switching capacity: 250VAC/10 (2) A, 120VAC/15 (2) A, DC 30W

接線方式: 2接點線徑2.5mm², 螺絲扭力0.6Nm

Wiring: 2 contacts diameter 2.5mm², screw torque 0.6Nm

外觀尺寸 Dimensions: 60 x 33 x 43mm

防護等級 IP Ratings: IP20



型號 Part No.	觸點形式 Contact Type	觸點電阻 Contact Resistance	安裝方式 Installation	溫度調節範圍 Temp.Range	重量 Weight
CT-KTA011	NO	<10mΩ	35mmDIN軌道	0°C~60°C	40g
CT-KTB011	NC				