

■ Dimensions, mm
Contactors/Open type

SC-N1, SC-N2

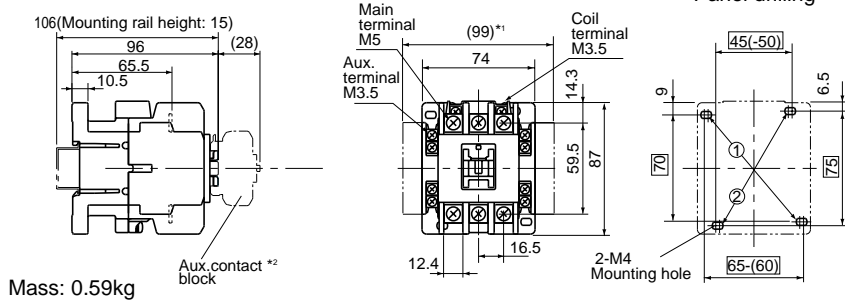

Mass: 0.59kg

SC-N2S, SC-N3

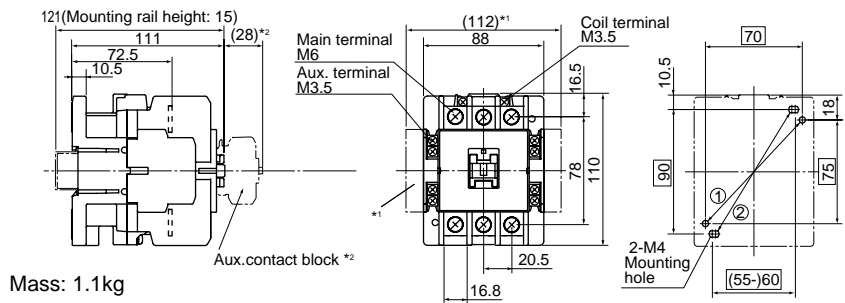

Mass: 1.1kg

SC-N4

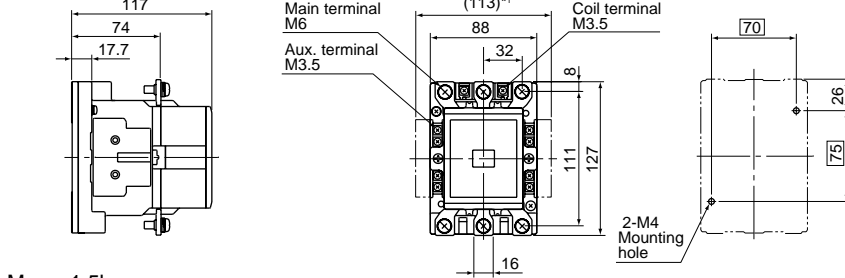

Mass: 1.5kg

SC-N5A

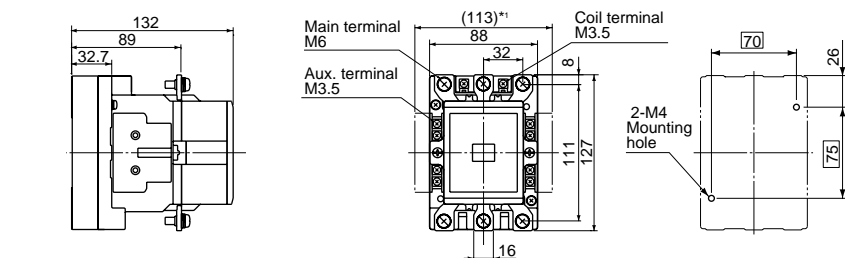

Mass: 1.5kg

SC-N6

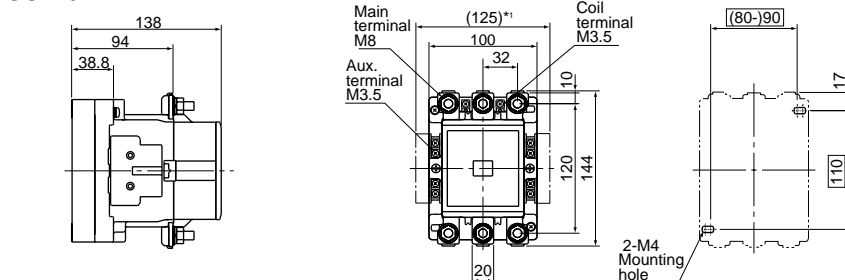

Mass: 2.4kg

■ Wiring diagrams
SC-N1 to SC-N16

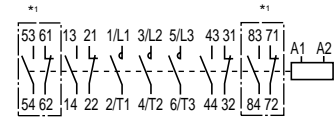

*1 In case of auxiliary contact 4NO+4NC

Note: • Use the two mounting holes on a diagonal line to mount a contactor.
 Mounting holes indicated by ① are compatible with those of SRC type.
 Mounting holes indicated by ② are compatible with IEC standard

*1 For two side mounting aux. contact blocks mounted

*2 For front mounting aux. contact blocks mounted